



**BELLE PLAINE PLANNING & ZONING COMMISSION  
NOTICE OF REGULAR MEETING AND AGENDA  
CITY HALL, 218 NORTH MERIDIAN STREET  
PLEASE USE THE NORTH ENTRANCE**

**MONDAY, APRIL 13, 2026  
6:00 P.M.**

**PLEDGE OF ALLEGIANCE**

6:00 **1. CALL TO ORDER.**  
P.M. 1.1. Roll Call.

**2. APPROVAL OF AGENDA.**

**3. APPROVAL OF MINUTES.**

5.1. Regular Session Minutes of February 9, 2026.

6:05 **4. RECOGNITION OF INVOLVED CITIZENS.**

P.M. *Persons may make statements to the Planning Commission pertaining to items **not** on the agenda. Maximum of three (3) minutes per speaker. No official action will be taken.*

**5. PUBLIC HEARINGS.**

5.1. **Variance: Impervious Surface Coverage 148 Chestnut Street South St. Johns Lutheran Church.** The Planning Commission will consider public comment on a variance to Section 1105.07 (5)(5) of the city code which limits the total lot surface coverage to 40% in the R-3 One and Two Family Residential District. The Applicant is requesting a variance to allow lot coverage exceeding 40% to accommodate additional off-street parking.

5.1.1. **Resolution PZ 26-04** Recommending the City Council Approve a Variance to Section 1105.07 (5)(5) of the City Code to Allow 85 Percent Impervious Surface Coverage on Lot 1, Block 1 St. Johns Lutheran Church, 148 Chestnut Street South.

5.2. **Preliminary Plat Valley Business Park Fourth.** The Planning Commission is to hold a public hearing on a preliminary plat for Valley Business Park Fourth. The proposed plat combines four parcels owned by the City of Belle Plaine.

5.2.1. **Resolution PZ 26-05** Recommending the City Council Approve a Preliminary Plat for Valley Business Park Fourth.

**6. BUSINESS.**

6.1. **Resolution PZ 26-06** Recommending City Council Approve a Final Plat for Valley Business Park Fourth.

6.2. 2050 Comprehensive Plan Update – Community Engagement.

**7. ADMINISTRATIVE REPORTS.**

7.1. Commissioner Comments.

7.2. Director's Report.

7.3. Upcoming Tentative Meetings.

1. Regular Meeting, 6:00 p.m., Monday, May 11, 2026.

**8. ADJOURNMENT.**

There may be a quorum of the Belle Plaine City Council present at the meeting.

**BELLE PLAINE PLANNING & ZONING COMMISSION  
REGULAR MEETING  
FEBRUARY 9, 2026**

**PLEDGE OF ALLEGIANCE**

Chair Romness led those present in the Pledge of Allegiance.

**1. CALL TO ORDER. 1.1. Roll Call.**

The Planning and Zoning Commission met in Regular Session on Monday, February 9, 2026 at City Hall 218 North Meridian Street, Belle Plaine, MN. Chair Romness called the meeting to order at 6:02 PM with Commissioners Crosby, Schmitz and Duklet present. Commissioners Elect Eggers and Walsh were also present.

Also present were Council Liaison Otto, Community Development Director Smith Strack and Assistant Community Development Director Gerold.

**2. OATHS OF OFFICE**

2.1. Jim Eggers, Antionette Walsh, Shelia Schmitz, and Brian Romness.

Community Development Director Smith Strack administered the Oath of Office for Commissioners Eggers, Walsh, Schmitz and Romness.

**3. APPROVAL OF AGENDA.**

MOTION by Commissioner Duklet, second by Commissioner Schmitz, to approve the Agenda as presented. ALL VOTED AYE. MOTION CARRIED.

**4. ELECTION OF OFFICERS**

Commissioner Duklet called for nominations for Chair.

MOTION by Commissioner Crosby, second by Commissioner Schmitz, to nominate Brian Romness as Chair. No other nominations were made. ALL VOTED AYE. MOTION CARRIED.

Chair Romness presided over the remainder of the election of officers and called for nominations for Vice-Chair.

MOTION by Commissioner Duklet, second by Commissioner Eggers, to nominate Sheila Schmitz as Vice Chair. No other nominations were made. ALL VOTED AYE. MOTION CARRIED.

Commissioner Romness called for nominations of secretary.

MOTION by Commissioner Duklet, second by Commissioner Schmitz, to nominate Doug Crosby as Secretary. No other nominations were made. ALL VOTED AYE. MOTION CARRIED.

**5. APPROVAL OF MINUTES.**

5.1. Regular Session Minutes of September 8, 2025.

5.2. Joint Session Minutes of October 6, 2025.

5.3. Joint Session Minutes of January 20, 2026.

MOTION by Commissioner Schmitz, second by Commissioner Eggers, to approve the Regular Session Minute of September 8, 2025, Joint Session Minutes of October 6, 2025 and Joint Session Minutes of January 20, 2026. ALL VOTED AYE. MOTION CARRIED.

**6. RECOGNITION OF INVOLVED CITIZENS.**

*Persons may make statements to the Planning Commission pertaining to items **not** on the agenda. Maximum of three (3) minutes per speaker. No official action will be taken.*

*No one stepped forward.*

**7. PUBLIC HEARINGS.**

**7.1. Preliminary Plat St. Johns Church. The Planning Commission is to hold a public hearing on a preliminary plat for St. Johns Church. The proposed plat combines three parcels owned by St. Johns Church.**

Assistant Community Development Director Gerold reviewed the Preliminary Plat for St. Johns Church with a slideshow. Gerold explained the three lots of record are proposed to be recorded into one single parcel.

The Commission asked clarifying questions.

Commissioner Romness opened the public hearing at 6:13 PM.

No one stepped forward.

MOTION by Commissioner Duklet, second by Commissioner Crosby, to close the public hearing at 6:13 PM. ALL VOTED AYE. MOTION CARRIED.

**7.1.1. Resolution PZ 26-01 Recommending the City Council Approve a Preliminary Plat for St. Johns Church.**

MOTION by Commissioner Duklet, second by Commissioner Schmitz, to approve Resolution PZ 26-01 Recommending the City Council Approve a preliminary Plat for St. Johns Church. ALL VOTED AYE. MOTION CARRIED.

**8. BUSINESS.**

**8.1. Resolution PZ 26-02 Recommending the City Council Approve a Final Plat for St. Johns Church.**

Assistant Community Development Director Gerold reviewed the Final Plat for St. Johns Church with a brief slideshow.

MOTION by Commissioner Schmitz, second by Commissioner Crosby, to approve Resolution PZ 26-02 Recommending the City Council Approve a Final Plat for St. Johns Church. ALL VOTED AYE. MOTION CARRIED.

**8.2. Resolution PZ 26-03 Recommending City Council Approve A Minor Subdivision 919 Church Street West.**

Assistant Community Development Director Gerold reviewed the Minor Subdivision lot split at 919 Church Street West, noting the single lot would be separated into two lots of record.

The Commission asked clarifying questions.

MOTION by Commissioner Duklet, second by Commissioner Schmitz, to approve Resolution PZ 26-03 Recommending City Council Approve a Minor Subdivision at 919 Church Street West. ALL VOTED AYE. MOTION CARRIED.

**8.3. 2050 Comprehensive Plan Update.**

Community Development Director Smith Strack reviewed a follow up report from the meeting with the Met Council. Smith Strack noted Councils request for additional information.

The Commission held discussion on timelines, benefits of the plan, and community engagement.

**8.4. PZC Roles & Responsibilities.**

Community Development Director Smith Strack reviewed the Planning and Zoning Commissions Roles and Responsibilities, the open meeting law, data practices law and conflict of interest.

**9. ADMINISTRATIVE REPORTS.**

**9.1. Commissioner Comments.**

Commissioner Romness welcomed the new members.

**9.2. Director's Report.**

Community Development Director Smith Strack explained the report is in the packet for review.

**9.3. Upcoming Tentative Meetings.**

1. Regular Meeting, 6:00 p.m., Monday, March 9, 2026.

The Commission was reminded of the next upcoming meeting as listed.

**10. ADJOURNMENT.**

MOTION by Commissioner Schmitz, second by Commissioner Eggers, to adjourn the meeting at 7:12 PM.  
ALL VOTED AYE. MOTION CARRIED.

Respectfully Submitted,

Renee Eyrich  
Recording Secretary



# MEMORANDUM

Planning and Zoning Commission

<b>DATE:</b>	April 13 <sup>th</sup> , 2026
<b>FROM:</b>	Jim Gerold, Asst. Community Development Director
<b>AGENDA ITEM:</b>	<u>Public Hearing: Site Coverage Variance</u> <u>Resolution PZ 26-04 (Specify A or B)</u> , Recommending the City Council Conditionally Approve (Deny) a Variance to increase the Site Coverage at 148 Chestnut St. S from 72% to 85%.
<b>BACKGROUND:</b>	<p>The Planning Commission is to hold a public hearing on a site coverage variance request.</p> <p>St Johns church requests a variance to increase allowable site coverage at 148 Chestnut St. S. The property was recently platted into one lot of record in order to accommodate additional parking. A site plan showing the expansion of a parking lot has been submitted to the City for zoning review. The Applicant requests a variance to standards for the maximum allowable site coverage under Section 1105.07, Subd. 5 (5) of the City Code.</p>  <p>Current site coverage of the property is 72%. The proposed coverage is 85%. The maximum allowable coverage is 40%.</p> <p>The increase in lot coverage would allow for the expansion of the existing parking lot.</p> <p>No change in the property use is proposed. The church is an existing conditional use within the R-3 Zoning District.</p>
<b>REVIEW:</b>	<p>Notice of the requested variance has been published, posted, and mailed. As of the drafting of this memo no public comment for or against the request have been received.</p> <p>Section 1105.07 Subd. 5(5) of the City Code limits the allowable site coverage of a parcel in the R-3 zoning district to 40%. The Applicant has provided a site plan for the expansion of an existing parking lot. To accommodate the expansion, the site plan depicts an increase in the Site Coverage from 72% to 84%.</p> <p>There is no change of use of the property proposed. The existing use is consistent with planned land use under Destination 2040 and existing zoning.</p> <p>Section 1103.05 of the Code establishes general and review criteria to be address during variance review as follows:</p> <ol style="list-style-type: none"><li>1. Variance must be in harmony with the general purposes and intent of the Code.</li><li>2. Variance must be consistent with the Comprehensive Plan.</li><li>3. Practical difficulties must exist, meaning:<ol style="list-style-type: none"><li>a. The property is to be used in a reasonable manner which is not permitted by the Code;</li><li>b. The plight of the property owner is due to circumstances unique to the property and not created by the landowner; and,</li></ol></li></ol>

	<p>c. The variance, if granted, will not alter the essential character of the locality.</p> <p><u>Potential Findings</u></p> <p>In favor of the request:</p> <ul style="list-style-type: none"> <li>• The current use of the property is consistent with both planned use and existing zoning.</li> <li>• Applicant has proposed adding landscaped areas with pervious surfaces in required setbacks and at the east side of parking lot.</li> <li>• Due to the location of the parcel in an existing, fully developed neighborhood, options for alternate or shared off-street parking are limited. The existing lot configuration and surrounding development constrain alternatives.</li> <li>• The additional off-street parking would move the property closer to compliance with required off-street parking standards, reducing parking and pedestrian traffic on nearby residential streets.</li> <li>• Due to cost, pervious paving options would be cost-prohibitive. While not a sole rationale for granting a variance, financial hardship may be considered</li> <li>• The proposed variance is to a performance standard and not a property use.</li> </ul> <p>In opposition to the request:</p> <ul style="list-style-type: none"> <li>• City Code does not require additional off-street parking be added. The existing parking lot could be left as-is.</li> <li>• Pervious paving options for parking lots are available and could be utilized to reduce lot coverage.</li> </ul> <p><u>Review Comments</u></p> <p>If the Planning Commission considers a favorable recommendation the following conditions are suggested:</p> <ol style="list-style-type: none"> <li>1. Any further expansion of the facility or changes to the site coverage shall require further zoning review.</li> <li>2. Incorporate any comments by City Engineer.</li> <li>3. This permit is subject to all applicable codes, regulations and ordinances, and violation thereof shall be grounds for revocation.</li> <li>4. The approval shall expire one year after date of approval unless applicant has commenced construction.</li> </ol>
<b>ACTION:</b>	The Planning Commission is hold a public hearing and make recommendations to the City Council pertaining to the parking variance.
<b>ATTACHMENTS:</b>	<ul style="list-style-type: none"> <li>• Site plans illustrating existing and proposed site coverage</li> <li>• Site Plan</li> <li>• Aerial map of locale.</li> <li>• <u>Resolution PZ 26-04(A)</u> Recommending the City Council Conditionally Approve a Variance increasing the allowable site coverage from 72% to 85%.</li> <li>• <u>Resolution PZ 26-4(B)</u> Recommending the City Council Deny a Variance increasing the allowable site coverage from 72% to 85%.</li> </ul>
<b>SIGNATURE:</b>	



**City of Belle Plaine**  
 218 N. Meridian Street  
 P.O. Box 129  
 Belle Plaine, MN 56011

**Community Development Department**  
**Phone:** 952-873-5553  
 cynthias@belleplainemn.com  
 www.belleplainemn.gov

**Fee:** \$300.00 Single-family Dwellings / \$500.00 all other applicants

## VARIANCE REQUEST APPLICATION

<b>PROPERTY</b>	Address:	P.I.N.:
-----------------	----------	---------

Lot(s):	Block(s):	Subdivision:
---------	-----------	--------------

Zoning:

<b>APPLICANT</b>	<input type="checkbox"/> <b>Owner</b>	Name:	Phone:
------------------	---------------------------------------	-------	--------

Address:	Cell:
----------	-------

E-mail:	Fax:
---------	------

<b>OWNER</b>	Name:	Phone:
--------------	-------	--------

Address:	Cell:
----------	-------

E-mail:	Fax:
---------	------

**Variance is requested to:**

<b>Ordinance in which variance is requested:</b>	Section Number:	Subdivision Number:
--	-----------------	---------------------

In your opinion, is the variance consistent with the purpose and intent of the ordinance?    **Yes**    **No**    *Explain:*

In your opinion, is the variance consistent with the comprehensive plan?    **Yes**    **No**    *Explain:*

In your opinion, does the proposal put property to use in a reasonable manner?    **Yes**    **No**    *Explain:*

In your opinion, are there circumstances unique to the property?    **Yes**    **No**    *Explain:*

In your opinion, will the variance maintain the essential character of the locality?    **Yes**    **No**    *Explain:*

**SUBMISSION OF APPLICATION MUST INCLUDE:**

- Attached site plan (to scale) depicting present and proposed improvements.

Within the time frame established by Minnesota Statutes section 15.99, following receipt of the completed application, the City Council shall render its decision granting or denying the variance. Such decision shall be accompanied by findings of fact and shall refer to any exhibits containing plans and specifications for the proposed variance. Such plans and specifications shall remain a part of the permanent records of the City Council. The findings of fact shall specify the reason or reasons for granting or denying the variance. The terms of relief granted shall be specifically set forth in a conclusion or statement separate from the findings of fact. In extenuating circumstances, extension of the sixty (60) days may be granted upon receipt of signed request from applicant.

An application for a variance shall be submitted to the Zoning Administrator. A nonrefundable application fee, established from time to time by the City Council to cover administrative costs and costs of the hearing, shall accompany each application. The application shall contain the following information, as well as such additional information as may be required by the Zoning Administrator:

- The applicant’s name and address.
- A site plan drawn to scale showing the property dimensions, existing and proposed buildings and other structures, existing and proposed grading, landscaping, easements and location of utilities, as applicable. The Zoning Administrator may require the applicant to obtain a certified survey at the time of application.
- The particular requirements of the Ordinance which prevent the proposed use or construction.
- The characteristics of the subject property which prevent compliance with the said requirements of the Ordinance.
- The minimum reduction of the requirements of the Ordinance which would be necessary to permit the proposed use or construction.
- The practical difficulty which would result if said particular requirements of this Ordinance were applied to the subject property.
- If the variance is part of an application for Commercial, Industrial, or Multiple-Family Residential Site Plan Approval, all of the submittal requirements for a Site Plan, Section 1103.07, shall also apply.

I certify that I am the applicant named herein; that I have familiarized myself with the rules and regulations with respect to preparing and filing this application that the foregoing statements and answers herein contained and the information on the attached maps or plot plans and any other documents submitted herewith are in all respects true and accurate to the best of my knowledge and behalf.

**APPLICANT SIGNATURE:** Jim Eggers **DATE:** \_\_\_\_\_

**OFFICE USE ONLY**

<b>Zoning:</b>	<b>Application Fee:</b>	<b>Form of Payment:</b>
		<b>Date:</b>
	<input type="checkbox"/> <b>Site Plan</b>	<b>Transaction Number:</b>
		<b>Collected By:</b>
<b>Reviewed by Community Development Director</b>	<input type="checkbox"/> <b>Application Complete</b>	<b>Date:</b>
<b>Reviewed by Planning Commission</b>	<input type="checkbox"/> <b>Tabled</b> <input type="checkbox"/> <b>Approved</b> <input type="checkbox"/> <b>Denied</b>	<b>Date:</b>
<b>Reviewed by City Council</b>	<input type="checkbox"/> <b>Tabled</b> <input type="checkbox"/> <b>Approved</b> <input type="checkbox"/> <b>Denied</b>	<b>Date:</b>

**Variance is requested to:**

Allow the proposed church parking lot improvement to exceed the maximum permitted 40% impervious surface coverage for the property as established by Section 1105.07 of the zoning ordinance. The variance is requested to allow the church to construct a parking lot that adequately serves the needs of its congregation, visitors, and community events associated with the existing church facility. A significant portion of the congregation consists of elderly members, making safe, convenient, and proximate parking particularly important. The additional impervious surface is necessary to provide sufficient parking, improve pedestrian safety, reduce the distance congregants must walk, and allow for safe and orderly traffic circulation on the property

**In your opinion, is the variance consistent with the purpose and intent of the ordinance?**

The requested variance is consistent with the purpose and intent of the ordinance, including Section 1105.07, Subd. 5(5). The impervious surface limitation is intended to promote responsible site design, manage stormwater, protect surrounding properties, and promote safe and orderly development while still allowing reasonable use of land within the zoning district. The proposed improvement supports those goals by creating a properly designed parking area that improves traffic circulation, pedestrian safety, and overall site organization.

The variance allows the church to address parking needs associated with an existing and longstanding institutional use without changing the nature or character of the property. By providing additional off street parking on the church property, the project will also help reduce parking pressure on nearby residential streets. The request represents a practical site improvement that allows the property to function more effectively while remaining aligned with the broader goals of the zoning ordinance.

**In your opinion, is the variance consistent with the comprehensive plan?**

The requested variance is consistent with the goals and policies of the City's Comprehensive Plan. The proposed parking lot improvement supports the continued use of the property as a church, an established institutional use that serves both the congregation and the broader community. The project will improve overall site functionality by providing organized parking, improving traffic circulation on the property, and enhancing pedestrian safety. Providing additional parking on the property will also help reduce parking demand on nearby residential streets during church services and events.

By creating a properly designed parking area, the project promotes safer vehicle and pedestrian movement, better accessibility to the church facility, and more orderly use of the property. The variance does not change the underlying use of the property or negatively impact surrounding land uses, and it supports the Comprehensive Plan's goals of maintaining community-serving institutions, encouraging safe site design, and promoting responsible development.

**In your opinion, does the proposal put property to use in a reasonable manner?**

The proposal puts the property to use in a reasonable manner. The requested variance would allow the church to make a modest improvement to the existing site by expanding and improving a small number of existing off street parking spaces located on that side of the church. The proposal does not change the use of the property or introduce a new activity, but instead improves the safety, organization, and functionality of parking that already exists in that area.

The improvement will provide a more clearly defined and safer parking area, improve traffic flow on the property, and create better pedestrian access to the church building. The proposal represents a limited and practical site improvement that allows the church to better utilize its property while maintaining compatibility with surrounding uses.

**In your opinion, are there circumstances unique to the property?**

There are circumstances unique to the property that support the requested variance. The church building on the property was constructed in 1911, long before modern zoning regulations and impervious surface limitations were adopted. As a result, the property was originally developed without the site design standards and parking expectations that exist today.

Since that time, both the congregation and the City of Belle Plaine have grown, resulting in greater parking needs than originally contemplated when the church was constructed. The configuration of the existing church building, access points, and surrounding streets limits the ability to significantly reorganize the site or relocate parking areas. The proposed improvement simply expands and formalizes a small number of off street parking spaces that already exist on that side of the church, improving safety and organization without altering the underlying use of the property. Because the property was developed over a century ago under very different planning standards, these circumstances are unique to the site and support the need for a limited variance.

**In your opinion, will the variance maintain the essential character of the locality?**

The requested variance will maintain the essential character of the locality. The property will continue to be used as a church, which has been a longstanding and familiar part of the surrounding neighborhood since the church building was constructed in 1911. The proposal does not introduce a new use or change the nature of the property, but instead improves an existing condition by formalizing and modestly expanding off street parking already located on that side of the church.

The improvement is intended to create a safer and more organized parking area, improve traffic circulation on the property, and provide better pedestrian access to the church building. Currently, much of the parking associated with church services and activities occurs on nearby residential streets. Providing additional off street parking on the church property will help reduce that impact while allowing the church to continue serving its congregation and the broader community.

The project represents a limited site improvement that supports the existing use of the property and remains compatible with the surrounding neighborhood. As a result, the variance will maintain, and in some respects improve, the overall character of the area.

Existing Lot Coverage = Approx. 72%



**Legend**

- City Limits
- Parcels 6/12/2025
- Lot Lines
- Minnesota River
- Protected Waters
  - Public Water Basin
  - Public Water Wetland
  - Protected Waters - Watercourse

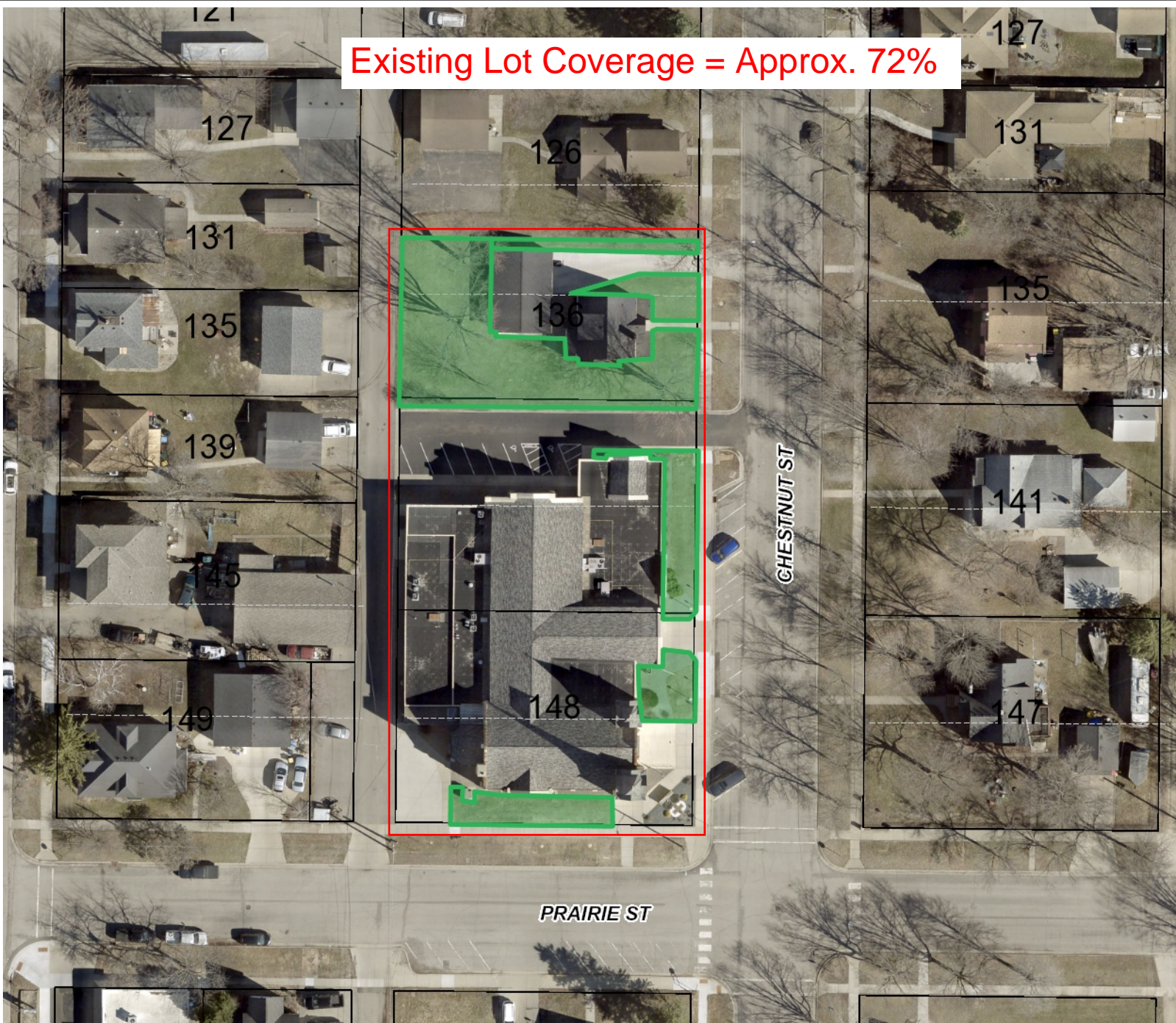

**Map Name**



**Disclaimer:**

This drawing is neither a legally recorded map nor a survey and is not intended to be used as one. This drawing is a compilation of records, information, and data located in various city, county, and state offices, and other sources affecting the area shown, and is to be used for reference purposes only. The City of Belle Plaine is not responsible for any inaccuracies herein contained.

0 66 Feet

Proposed Lot Coverage = Approx. 85%

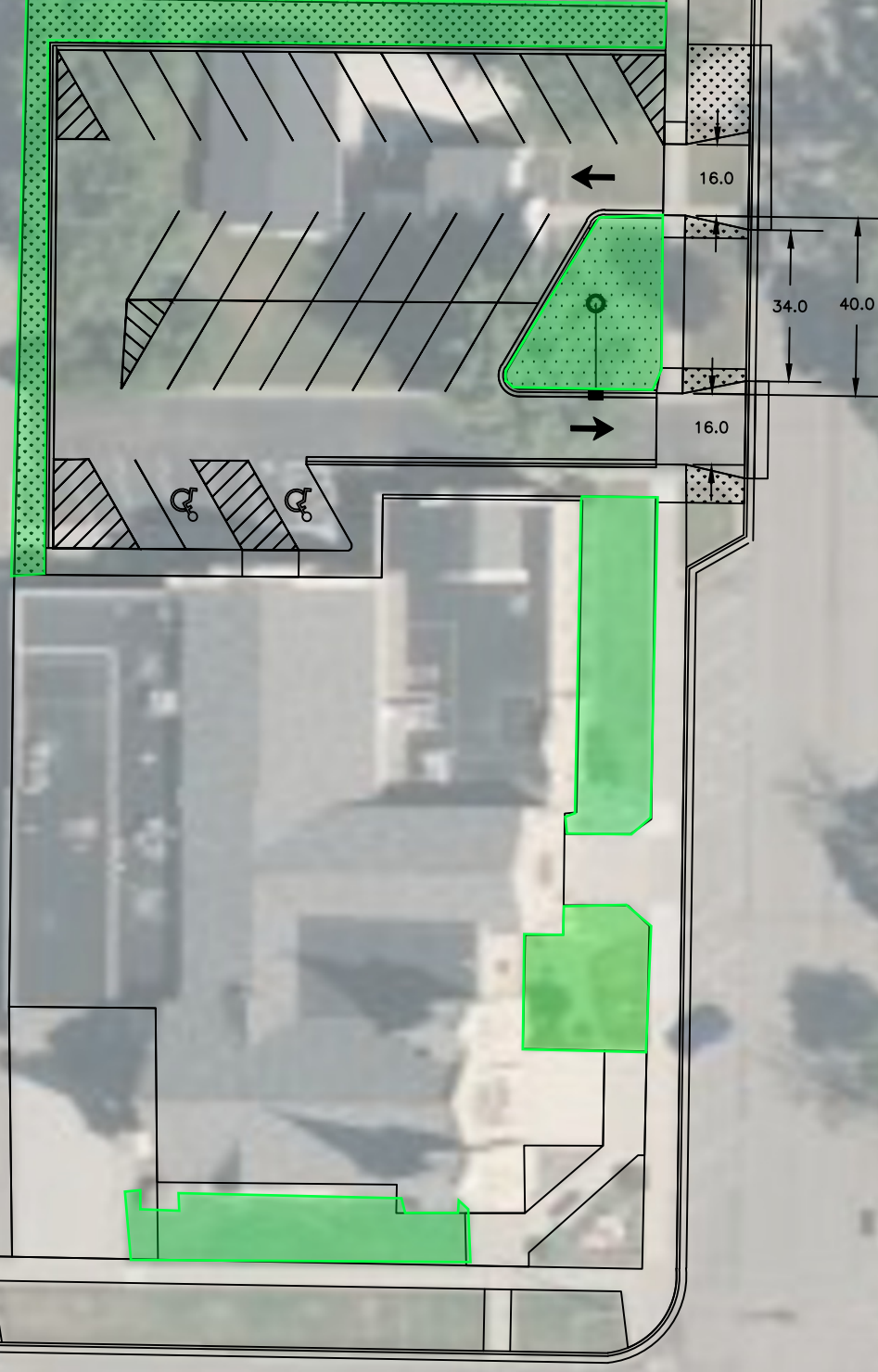

NIELSEN  
BLACKTOPPING  
INC.

MARK	DESCRIPTION	DATE	APP.
<<			
<<			
<<			
<<			
<<			
<<			
<<			
<<			
<<			
<<			
<<			

DESIGNED BY \_\_\_\_\_ DATE \_\_\_\_\_  
DRAWN BY \_\_\_\_\_  
CHECKED BY \_\_\_\_\_  
ASBUILT BY \_\_\_\_\_

REVISION \_\_\_\_\_  
DATE \_\_\_\_\_

SCALES  
N/A  
VERTICAL  
0 20  
HORIZONTAL

NIELSEN BLACKTOPPING INC.  
305 INDUSTRIAL ST E  
KASOTA, MINNESOTA 56050

ST JOHN'S LUTHERN CHURCH  
FROM STATION N/A  
TO STATION N/A

PROJECT NO. \_\_\_\_\_ SAP. \_\_\_\_\_ FED PROJ NO. \_\_\_\_\_

SHEET REFERENCE NUMBER:  
**N/A**

SHEET \_\_\_\_\_ OF \_\_\_\_\_ SHEETS

**NOTES**

1. PAVEMENT STRIPING TO BE 4" WIDE WHITE PAINTED STRIPE. ACCESSIBLE ACCESS AISLE STRIPING SHALL BE 4" WIDE WHITE PAINTED STRIPE 18" ON CENTER AND AT 45 DEGREE ANGLES TO STALL.
2. ALL RADII MEASURED TO BACK OF CURB.
3. ALL INSIDE BURB DIMENSIONS ARE TO THE FACE OF CURB UNLESS NOTED OTHERWISE.
4. THE CONTRACTOR SHALL COMPLY WITH ALL APPLICABLE PROVISIONS OF FEDERAL, STATE AND LOCAL SAFETY LAWS AND BUILDING CODES. ALL WORKMANSHIP SHALL COMPLY WITH THE OCCUPATIONAL SAFETY AND HEALTH ADMINISTRATION STANDARDS.
5. ALL FEES AND PERMITS SHALL BE THE RESPONSIBILITY OF THE INSTALLING CONTRACTOR UNLESS NOTED OTHERWISE.
6. THE CONTRACTOR IS RESPONSIBLE FOR PROTECTING EXISTING STRUCTURES, UTILITIES, WALKS, CURB AND PAVEMENT FROM DAMAGE.
7. ALL WORK MUST BE IN ACCORDANCE WITH THE ADA STANDARDS FOR ACCESSIBLE DESIGN AS PUBLISHED IN THE TITLE III REGULATIONS (28 CFR PART 36) PUBLISHED SEPTEMBER 15, 2010 ISSUED BY THE DEPARTMENT OF JUSTICE.
8. IT IS RECOMMENDED THAT THE CONTRACTOR NOTIFY GOPHER ONE STATE ONE CALL AT 811 AT LEAST 72 HOURS PRIOR TO CONSTRUCTION.

**CONSTRUCTION KEYED NOTES**

- ① CONCRETE PAVEMENT PARKING LOT
- ② B612 CONCRETE CURB & GUTTER. REFER TO DETAIL SHEET.
- ③ CONCRETE DRIVEWAY APRON PER CITY SPECIFICATIONS. SAWCUT EXISTING CURB/GUTTER AND BITUMINOUS PAVEMENT AS NEEDED TO INSTALL APRON. PAVEMENT TO MATCH EXISTING THICKNESSES OR PER DETAIL, WHICH EVER IS GREATER. LIMITS OF REMOVAL/REPLACEMENT SHALL BE APPROVED BY PUBLIC WORKS. CONCRETE CURB SHALL MATCH EXISTING TYPE AND FLOWLINE. DRIVEWAY APRON SHALL MATCH EXISTING GUTTER FLOWLINE.
- ④ CONCRETE SIDEWALK
- ⑤ TAPER CURB DOWN 6" IN 3'.
- ⑥ 2.17' WIDE FLAT CURB CUT OPENING

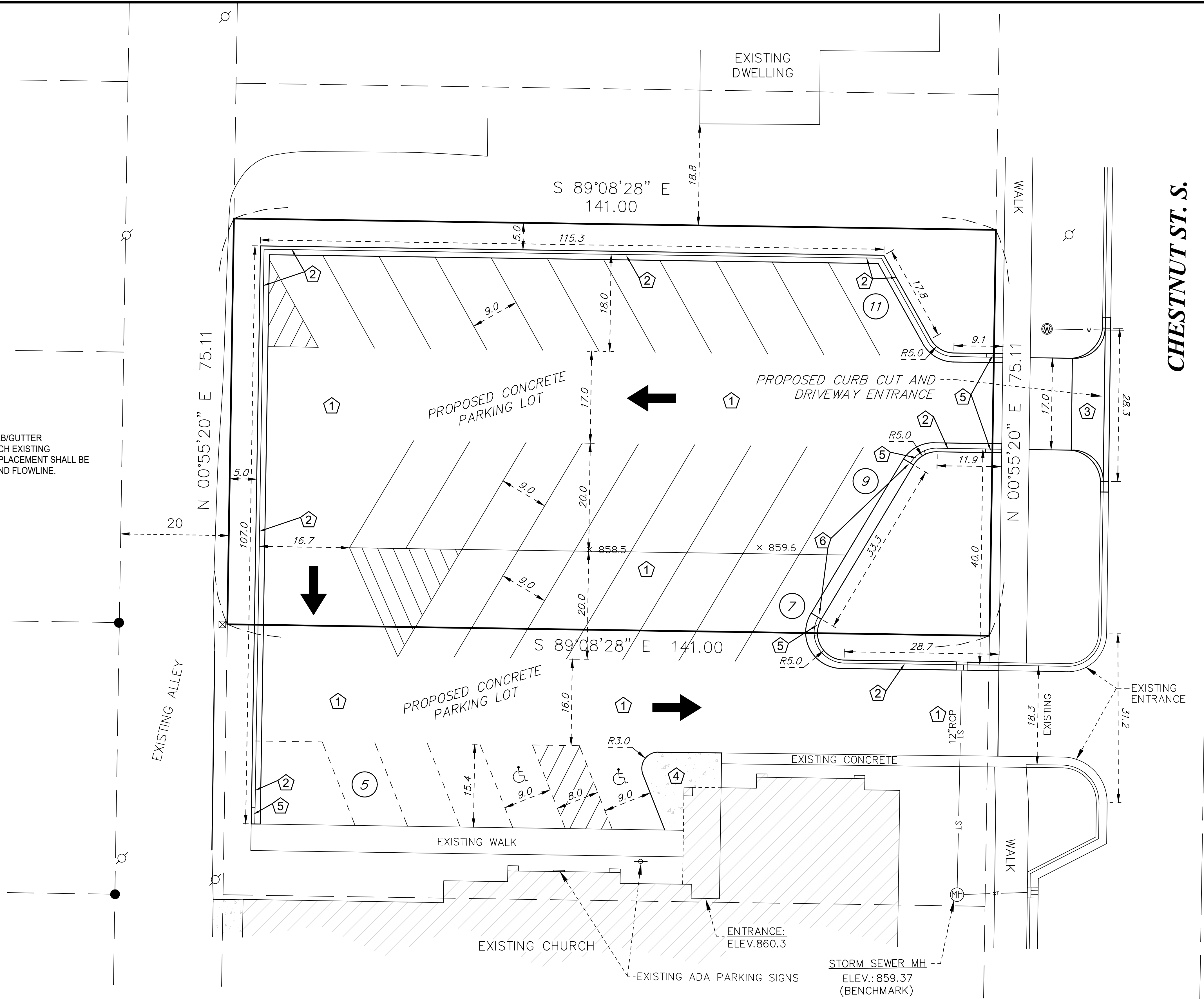

DATE	REVISION DESCRIPTION

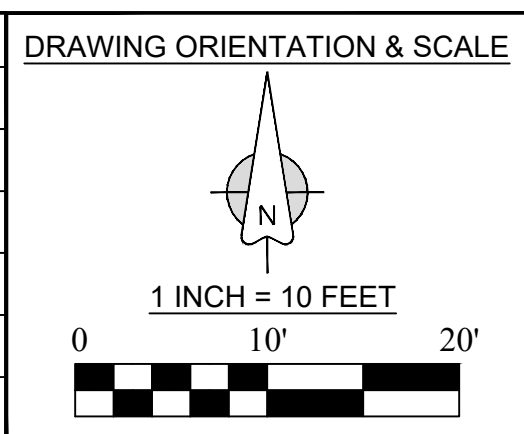

**CLIENT/JOB ADDRESS**

**ST. JOHN LUTHERAN CHURCH**

136 CHESTNUT STREET SOUTH  
BELLE PLAIN, MN

**Advance**  
Surveying & Engineering Co.

18202 Minnetonka Blvd. Suite 401  
Deephaven, Minnesota 55391  
Phone (952) 474-7964  
Web: www.advsur.com

I HEREBY CERTIFY THAT THIS PLAN, SPECIFICATION OR REPORT WAS PREPARED BY ME OR UNDER MY DIRECT SUPERVISION AND THAT I AM A DULY LICENSED PROFESSIONAL ENGINEER UNDER THE LAWS OF THE STATE OF MINNESOTA.

*Josetta S. Rinke*  
# 52716  
LICENSE NO.  
APRIL 3, 2026  
DATE

DATE SURVEYED: MARCH 23, 2026

SURVEYED BY:  
WAYNE W. PREUS, PLS. #43503  
ADVANCE SURVEYING & ENG., CO.

DRAFTED DATE:  
APRIL 3, 2026

**SHEET TITLE**  
PROPOSED SITE PLAN

SHEET SIZE: 22 X 34

**DRAWING NUMBER**  
260325 JR

**SHEET NO.**  
**C1**

SHEET 1 OF 2

**NOTES**

1. ALL CONSTRUCTION AS CALLED FOR ON THESE CONTRACT DOCUMENTS SHALL BE PERFORMED IN ACCORDANCE WITH ALL OSHA REQUIREMENTS.
2. SPOT ELEVATIONS/CONTOURS SHOWN AS FINISHED GRADE ELEVATIONS.
3. CURB & GUTTER SPOT ELEVATIONS ARE TO GUTTER LINE.
4. POSITIVE DRAINAGE OF MINIMUM 2% SLOPE SHALL BE ACHIEVED AWAY FROM PROPOSED BUILDING.
5. IT IS RECOMMENDED THAT THE CONTRACTOR NOTIFY GOPHER ONE STATE ONE CALL AT 811 AT LEAST 72 HOURS PRIOR TO CONSTRUCTION.

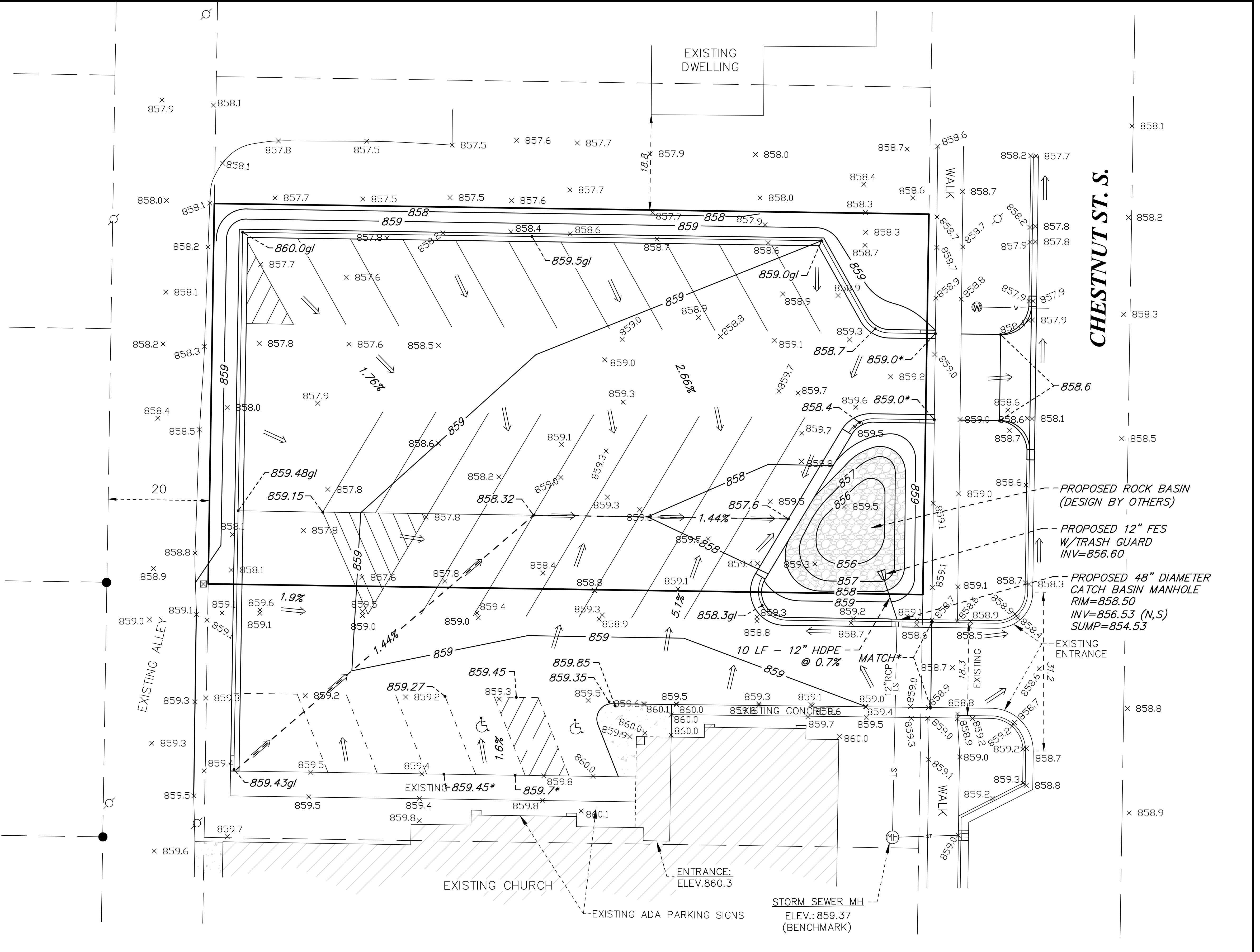

**LEGEND**

- EXISTING CONTOUR --- 835 ---
- EXISTING SPOT ELEVATION x 835.5
- PROPOSED CONTOUR — 859 —
- PROPOSED SPOT ELEVATION — 859.43g1
- DRAINAGE ARROW - FLOW →

DATE	REVISION DESCRIPTION

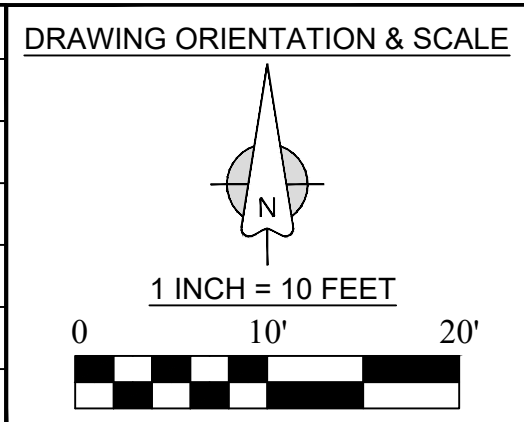

CLIENT/JOB ADDRESS

**ST. JOHN LUTHERAN CHURCH**

136 CHESTNUT STREET SOUTH  
BELLE PLAIN, MN

**Advance**  
Surveying & Engineering Co.

18202 Minnetonka Blvd. Suite 401  
Deephaven, Minnesota 55391  
Phone (952) 474-7964  
Web: www.advsur.com

I HEREBY CERTIFY THAT THIS PLAN, SPECIFICATION OR REPORT WAS PREPARED BY ME OR UNDER MY DIRECT SUPERVISION AND THAT I AM A DULY LICENSED PROFESSIONAL ENGINEER UNDER THE LAWS OF THE STATE OF MINNESOTA.

*Josetta S. Rinke*  
# 52716  
LICENSE NO.  
APRIL 3, 2026  
DATE

DATE SURVEYED: MARCH 23, 2026

SURVEYED BY:  
WAYNE W. PREUS, PLS. #43503  
ADVANCE SURVEYING & ENG., CO.

DRAFTED DATE:  
APRIL 3, 2026

SHEET TITLE  
**PROPOSED GRADING & UTILITY PLAN**

SHEET SIZE: 22 X 34

DRAWING NUMBER  
**260325 JR**

SHEET NO.

**C2**

SHEET 2 OF 2

**BELLE PLAINE PLANNING COMMISSION  
RESOLUTION PZ-26-04(A)**

**RECOMMENDING THE CITY COUNCIL APPROVE A VARIANCE TO SECTION 1105.07 (5)(5) OF THE  
CITY CODE TO ALLOW 85 PERCENT IMPERVIOUS SURFACE COVERAGE ON LOT 1, BLOCK 1 ST  
JOHNS LUTHERAN CHURCH, 148 CHESTNUT STREET SOUTH**

WHEREAS, City Code §1103.07 provides for the processing of variance requests; and,

WHEREAS, St Johns EV Lutheran Church is the fee owner of property at 840 Main Street East, legally described as Lot 1, Block 1, St Johns Lutheran Church; and,

WHEREAS, the subject parcel is zoned R-3 Single and Two Family Residential District; and,

WHEREAS, City Code §1105.07 (5)(5) of the City Code sets the maximum impervious surface coverage in the R-3 District at 40 percent of the lot; and,

WHEREAS, the subject property is currently over the maximum impervious surface coverage; and,

WHEREAS, the property owner has applied for a variance to allow increased impervious surface coverage to accommodate a parking lot expansion; and,

WHEREAS, a public hearing was scheduled and held by the Planning Commission, the City's designated Planning Agency, on April 13, 2026 following duly published, posted, and mailed notice; and,

WHEREAS, the Planning Commission accepted public input and discussed the proposed variance; and,

WHEREAS, the Planning Commission finds:

1. The current use of the property is consistent with both planned use and existing zoning.
2. Applicant has proposed adding landscaped areas with pervious surfaces in required setbacks and at the east side of parking lot.
3. Due to the location of the parcel in an existing, fully developed neighborhood, options for alternate or shared off-street parking are limited. The existing lot configuration and surrounding development constrain alternatives.
4. The additional off-street parking would move the property closer to compliance with required off-street parking standards, reducing parking and pedestrian traffic on nearby residential streets.
5. Due to cost, pervious paving options would be cost-prohibitive. While not a sole rationale for granting a variance, financial hardship may be considered
6. The proposed variance is to a performance standard and not a property use.

NOW, THEREFORE BE IT RESOLVED BY THE PLANNING COMMISSION OF THE CITY OF BELLE PLAINE, SCOTT COUNTY, MINNESOTA, THAT: It recommends the City Council approve a variance from §1105.07 (5)(5) of the City Code to provide up to 85 percent surface coverage on Lot 1, Block 1, St Johns Lutheran Church, provided:

1. Any further expansion of the facility or changes to the site coverage shall require further zoning review.
2. Incorporate any comments by City Engineer.
3. This permit is subject to all applicable codes, regulations and ordinances, and violation thereof shall be grounds for revocation.
4. The approval shall expire one year after date of approval unless applicant has commenced construction.

The adoption of the foregoing resolution was duly moved by Commissioner and seconded by Commissioner , and after full discussion thereof and upon a vote being taken thereon, the following Commissioners voted in favor thereof:

and the following voted against the same: .

Whereupon said resolution was declared duly passed and adopted. Dated this 13<sup>th</sup> day of April, 2026.

---

Brian Romness  
Chairperson

---

Cynthia Smith Strack  
Community Development Director

**RESOLUTION 26-04(A)**  
**EXHIBIT A**  
**SITE PLAN**

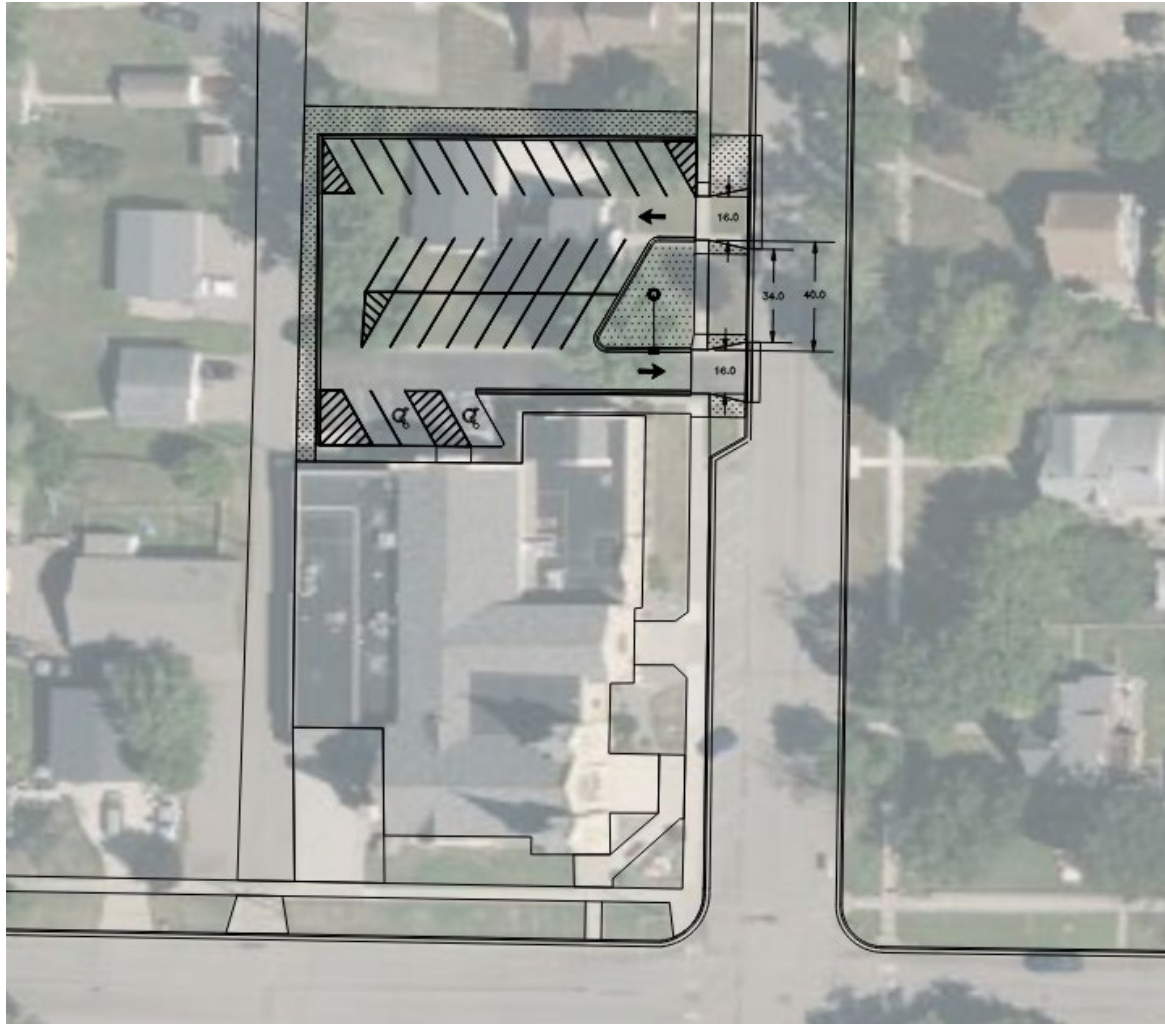

**BELLE PLAINE PLANNING COMMISSION  
RESOLUTION PZ-26-04(B)**

**RECOMMENDING THE CITY COUNCIL DENY A VARIANCE TO SECTION 1105.07 (5)(5) OF THE CITY CODE TO ALLOW 85 PERCENT IMPERVIOUS SURFACE COVERAGE ON LOT 1, BLOCK 1 ST JOHNS LUTHERAN CHURCH, 148 CHESTNUT STREET SOUTH**

WHEREAS, City Code §1103.07 provides for the processing of variance requests; and,

WHEREAS, St Johns EV Lutheran Church is the fee owner of property at 840 Main Street East, legally described as Lot 1, Block 1, St Johns Lutheran Church; and,

WHEREAS, the subject parcel is zoned R-3 Single and Two Family Residential District; and,

WHEREAS, City Code §1105.07 (5)(5) of the City Code sets the maximum impervious surface coverage in the R-3 District at 40 percent of the lot; and,

WHEREAS, the subject property is currently over the maximum impervious surface coverage; and,

WHEREAS, the property owner has applied for a variance to allow increased impervious surface coverage to accommodate a parking lot expansion; and,

WHEREAS, a public hearing was scheduled and held by the Planning Commission, the City's designated Planning Agency, on April 13, 2026 following duly published, posted, and mailed notice; and,

WHEREAS, the Planning Commission accepted public input and discussed the proposed variance; and,

WHEREAS, the Planning Commission finds:

1. City Code does not require additional off-street parking be added. The existing parking lot could be left as-is.
2. Pervious paving options for parking lots are available and could be utilized to reduce lot coverage.

NOW, THEREFORE BE IT RESOLVED BY THE PLANNING COMMISSION OF THE CITY OF BELLE PLAINE, SCOTT COUNTY, MINNESOTA, THAT: It recommends the City Council deny a variance from §1105.07 (5)(5) of the City Code to provide up to 85 percent surface coverage on Lot 1, Block One St Johns Lutheran Church.

The adoption of the foregoing resolution was duly moved by Commissioner and seconded by Commissioner , and after full discussion thereof and upon a vote being taken thereon, the following Commissioners voted in favor thereof:.

and the following voted against the same: .

Whereupon said resolution was declared duly passed and adopted. Dated this 13<sup>th</sup> day of April, 2026.

---

Brian Romness  
Chairperson

---

Cynthia Smith Strack  
Community Development Director



# MEMORANDUM

Planning and Zoning Commission

<b>DATE:</b>	April 13, 2026
<b>FROM:</b>	Jim Gerold, Asst. Community Development Director
<b>AGENDA ITEM:</b>	5.2: Preliminary Plat Valley Business Park Fourth
<b>REVIEW:</b>	<p>Valley Business Park Fourth is a proposed resubdivision of four parcels owned by the City of Belle Plaine. The proposed plat combines four lots into a single lot of record.</p> <p>Combining the four existing lots into one single lot of record will allow for added flexibility for future use of the property.</p> <p><u>Consistency with Comprehensive Plan</u> The plat is consistent with Destination 2040 and associated system plans.</p> <p><u>Proposed Land Use</u> The subject property is zoned IC Industrial/Commercial</p> <p><u>Public Hearing Notice</u> Notice of public hearing was mailed to adjacent property owners, posted and published in the Official Newspaper. No comments have been received as of the drafting of this memo.</p> <p><u>Department Review</u> City staff have reviewed the preliminary plat and find it consistent with Destination 2040 and local controls. Vacation of internal drainage/utility easements will be considered by Council.</p>
<b>ACTION:</b>	The Planning Commission is to hold a public hearing and take comments on the proposed plat. Following hearing and discussion the Planning Commission is to make a recommendation to the City Council.
<b>ATTACHMENTS:</b>	<ul style="list-style-type: none"> <li>• Preliminary plat – Valley Business Park Fourth.</li> <li>• Resolution PZ 26-05 - Recommending the City Council Approve a Preliminary Plat for Valley Business Park Fourth.</li> </ul>
<b>SIGNATURE:</b>	



# PRELIMINARY PLAT OF VALLEY BUSINESS PARK FOURTH

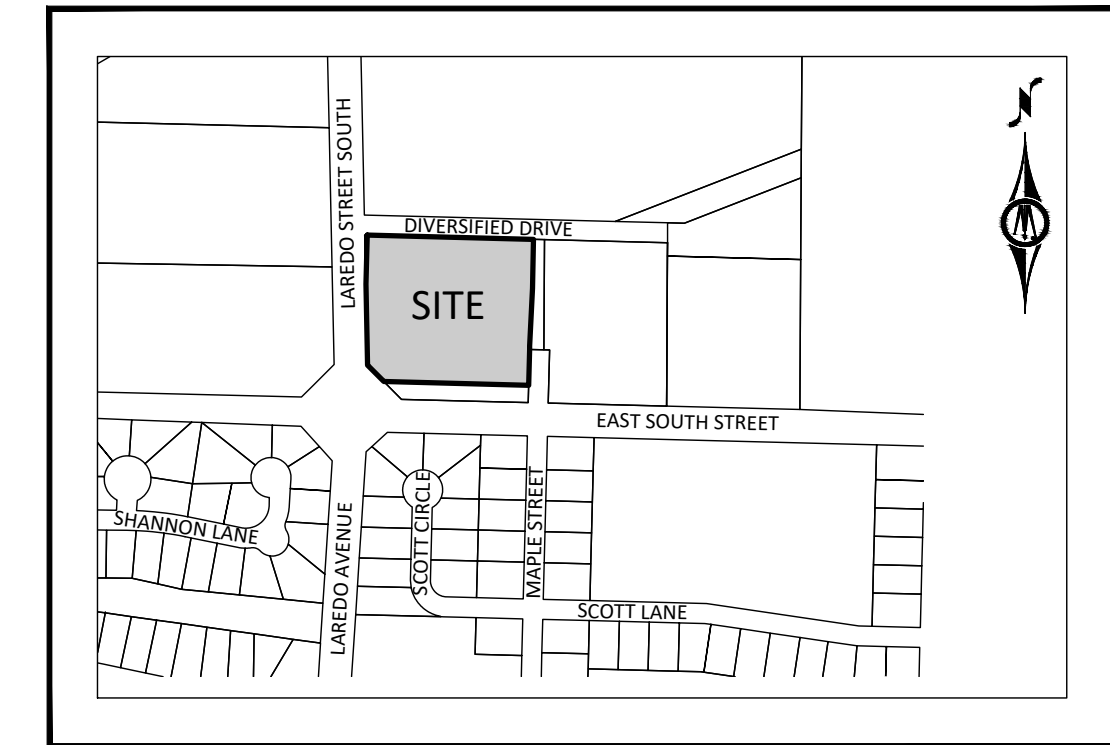

VICINITY MAP  
CITY OF BELLE PLAINE  
NOT TO SCALE

## UTILITY & SITE DATA

All Zoning, Setback information was obtained from the City of Belle Plaine. For detailed zoning information and specific interpretation of code requirements, contact the City of Belle Plaine Zoning Office.

ZONING: subject property - I-C (Industrial/Commercial District)

### SETBACKS I-C:

Front 35'  
Side 20'  
Interior Lot: 20'  
55' abutting a Residential District  
Corner Lot: 30'  
Rear 25'  
55' abutting a Residential District

Where railroad loading facilities exist or are to be provided, the rear and side yards may be modified through a variance.

Site Coverage: 85 percent and shall be calculated to include building footprints; parking areas; driveways; loading, storage and trash areas and other areas covered by an impervious surface.

HEIGHT RESTRICTION: Maximum Height 35'

UTILITIES: Underground utility lines and structures are shown in an approximate way only, according to information provided by others. A request that utilities be located for this survey was made through Gopher State One Call (Ticket No. 260650955). The underground utility lines and structures shown on this map represent the information provided to Bolton & Menk, Inc. as a result of that request. The surveyor does not guarantee that the information provided was either complete or accurate. The surveyor does not guarantee that there are no other underground utility lines and structures, active or abandoned, on or adjacent to the subject property.

## DESCRIPTION OF PROPERTY

Lot 1, Lot 2, Lot 3 and Lot 4, Block 1, VALLEY BUSINESS PARK THIRD, Scott County, Minnesota.

## SURVEYOR'S CERTIFICATION

I hereby certify that this survey, plan, or report was prepared by me or under my direct supervision and that I am a duly Licensed Land Surveyor under the laws of the State of Minnesota.

*Janele Fowlds* 3/31/2026  
Janele Fowlds Date  
License Number 26748

SHEET 1 OF 2

## LEGEND

- MONUMENT FOUND
- Ⓢ MANHOLE-SANITARY
- WATER SYSTEM
- - - SANITARY SEWER
- INTERMEDIATE CONTOURS
- INDEX CONTOURS

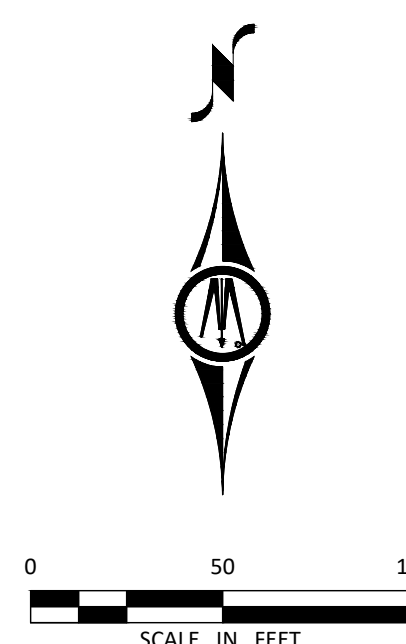

Horizontal Datum: Scott County Coordinate System (1996 Adj.)

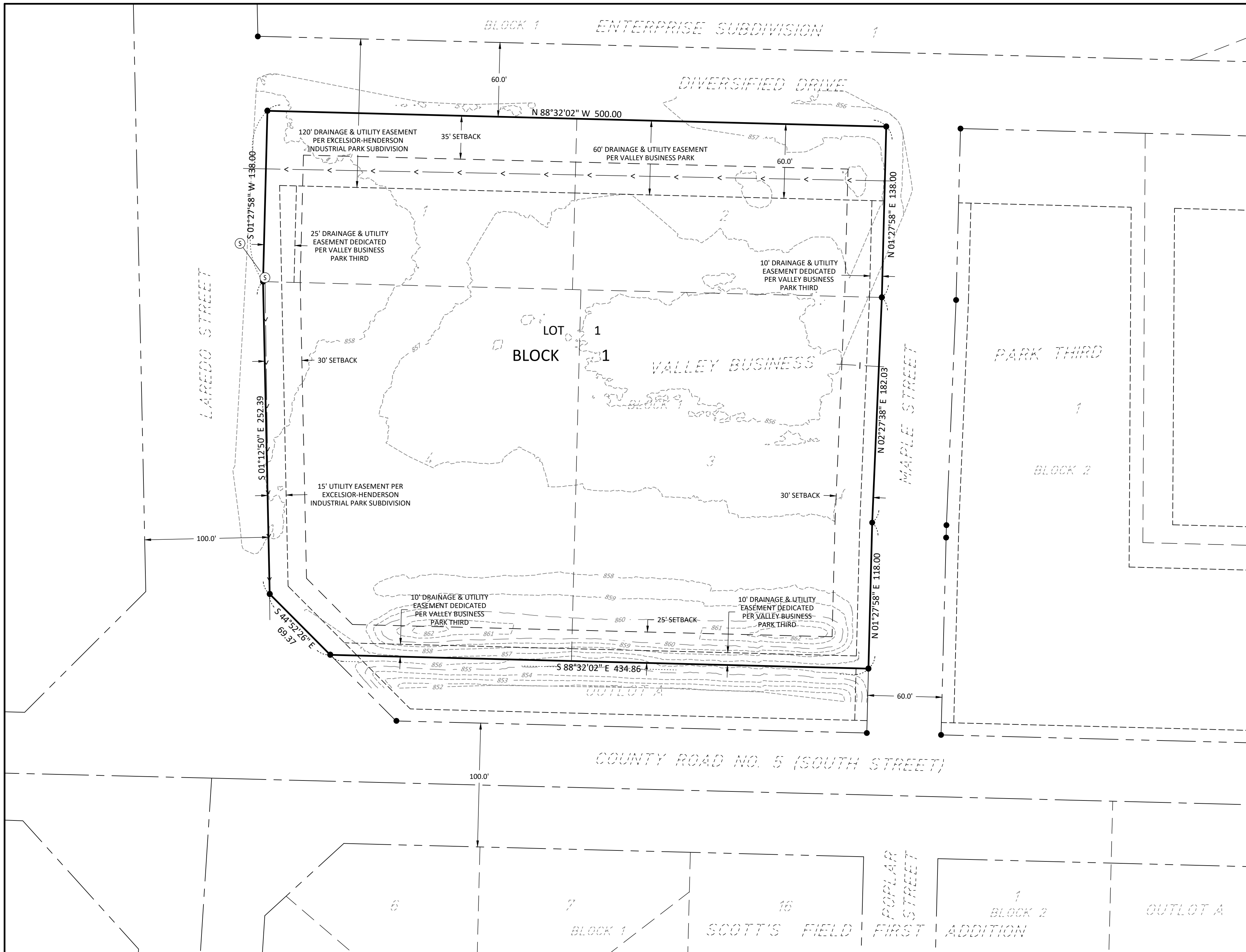

PRELIMINARY PLAT  
BELLE PLAINE, MINNESOTA

1960 Premier Drive  
Mankato, MN 56001  
Phone: (507) 625-4171

FOR: BELLE PLAINE, CITY OF

# PRELIMINARY PLAT OF VALLEY BUSINESS PARK FOURTH



VICINITY MAP  
CITY OF BELLE PLAINE  
NOT TO SCALE

## UTILITY & SITE DATA

All Zoning, Setback information was obtained from the City of Belle Plaine. For detailed zoning information and specific interpretation of code requirements, contact the City of Belle Plaine Zoning Office.

ZONING: subject property - I-C (Industrial/Commercial District)

### SETBACKS I-C:

- Front 35'
- Side 20'
- Interior Lot: 20'
- 55' abutting a Residential District
- Corner Lot: 30'
- Rear 25'
- 55' abutting a Residential District

Where railroad loading facilities exist or are to be provided, the rear and side yards may be modified through a variance.

Site Coverage: 85 percent and shall be calculated to include building footprints; parking areas; driveways; loading, storage and trash areas and other areas covered by an impervious surface.

HEIGHT RESTRICTION: Maximum Height 35'

UTILITIES: Underground utility lines and structures are shown in an approximate way only, according to information provided by others. A request that utilities be located for this survey was made through Gopher State One Call (Ticket No. 260650955). The underground utility lines and structures shown on this map represent the information provided to Bolton & Menk, Inc. as a result of that request. The surveyor does not guarantee that the information provided was either complete or accurate. The surveyor does not guarantee that there are no other underground utility lines and structures, active or abandoned, on or adjacent to the subject property.

## DESCRIPTION OF PROPERTY

Lot 1, Lot 2, Lot 3 and Lot 4, Block 1, VALLEY BUSINESS PARK THIRD, Scott County, Minnesota.

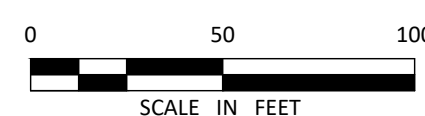

Horizontal Datum: Scott County Coordinate System (1996 Adj.)

## LEGEND

- MONUMENT FOUND
- Ⓢ MANHOLE-SANITARY
- WATER SYSTEM
- - - SANITARY SEWER
- · - · - INTERMEDIATE CONTOURS
- - - - INDEX CONTOURS

PRELIMINARY PLAT BELLE PLAINE, MINNESOTA		VALLEY BUSINESS PARK FOURTH LOTS 1-4, BLOCK 1, VALLEY BUSINESS PARK THIRD, BELLE PLAINE, SCOTTY COUNTY, MINNESOTA FOR: BELLE PLAINE, CITY OF
	1960 Premier Drive Mankato, MN 56001 Phone: (507) 625-4171	

**BELLE PLAINE PLANNING COMMISSION  
RESOLUTION PZ 26-05**

**RESOLUTION RECOMMENDING APPROVAL OF A PRELIMINARY PLAT  
FOR VALLEY BUSINESS PARK FOURTH**

**PID: 201030010, 201030020, 201030040 & 201030030**

**Legal: Lot 1, Lot 2, Lot3, and Lot 4, Block 1, Valley Business Park Third, Scott County, Minnesota**

WHEREAS, The City of Belle Plaine owns the aforementioned properties; and,

WHEREAS, the Planning and Zoning Commission has conducted a public hearing on the preliminary plat of Valley Business Park Fourth on April 13<sup>th</sup>, 2026, following posted, mailed, and published notice; and,

WHEREAS, the Planning and Zoning Commission has reviewed the plat as it relates to the City's Comprehensive Plan and Code standards and finds:

1. The subject property is owned by the City of Belle Plaine.
2. The plat appears to be consistent with the Comprehensive Plan and applicable zoning districts.
3. No subdivision improvements are required.

NOW THEREFORE BE IT RESOLVED BY THE PLANNING COMMISSION OF THE CITY OF BELLE PLAINE THAT: It hereby recommends the City Council approve a preliminary plat for Valley Business Park Fourth.

The adoption of the foregoing resolution was duly moved by Commissioner \_\_\_\_\_ and seconded by Commissioner, \_\_\_\_\_ and after full discussion thereof and upon a vote being taken thereon, the following Commissioners voted in favor thereof:

and the following voted against the same: .

Whereupon said resolution was declared duly passed and adopted. Dated this 13<sup>th</sup> day of April, 2026.

\_\_\_\_\_  
Brian Romness  
Planning Commission Chairperson

\_\_\_\_\_  
Cynthia Smith Strack  
Community Development Director





# MEMORANDUM

Planning and Zoning Commission

<b>DATE:</b>	April 13 <sup>th</sup> , 2026
<b>FROM:</b>	Jim Gerold, Asst. Community Development Director
<b>AGENDA ITEM:</b>	6.1. Final Plat Valley Business Park Fourth
<b>REVIEW:</b>	<p>The City of Belle Plaine owns four separate parcels at the intersection of South St. E and Laredo St. The attached plat will combine the four parcels into one lot of record.</p> <p>Platting would provide for increased flexibility in the use of the property.</p> <p>A public hearing was held earlier tonight for the corresponding Preliminary Plat.</p> <p>The City Attorney is completing a title review. Any comments will be incorporated into the final plat before the City Council</p> <p>Scott County is performing a plat check. Any comments will be incorporated into the final plat before the City Council.</p>
<b>ACTION:</b>	Review/recommendation to Council
<b>ATTACHMENTS:</b>	Final Plat - Valley Business Park Fourth Resolution 26-06 - Resolution Recommending City Council Approve a Final Plat for Valley Business Park Fourth.
<b>SIGNATURE:</b>	





**BELLE PLAINE PLANNING COMMISSION  
RESOLUTION PZ 26-06**

**RESOLUTION RECOMMENDING APPROVAL OF A FINAL PLAT  
FOR VALLEY BUSINESS PARK FOURTH**

**PID: 201030010, 201030020, 201030040 & 201030030**

**Legal: Lot 1, Block 1, Valley Business Park Fourth, Scott County, Minnesota**

WHEREAS, The City of Belle Plaine is resubdividing the aforementioned lots to combine said parcels into a single lot of record; and,

WHEREAS, the subject property is zoned I-C Industrial/Commercial District; and,

WHEREAS, the Planning Commission on April 13<sup>th</sup>, 2026, approved Resolution 26-05 recommending approval of the preliminary plat as presented; and,

WHEREAS, the Planning Commission has reviewed the final plat for Valley Business Park Fourth and finds:

1. The final plat is consistent with a preliminary plat recommended for approval by the Belle Plaine Planning Commission on April 13<sup>th</sup>, 2026.
2. The City Attorney is completing title review.
3. No plat improvements are required, therefore design standards and financing are not relevant

NOW, THEREFORE BE IT RESOLVED BY THE PLANNING COMMISSION OF THE CITY OF BELLE PLAINE, SCOTT COUNTY, MINNESOTA, THAT: It recommends the City Council approve a final plat for Valley Business Park Fourth, attached hereto as Exhibit A.

The adoption of the foregoing resolution was duly moved by Commissioner \_\_\_\_\_ and seconded by Commissioner \_\_\_\_\_, and after full discussion thereof and upon a vote being taken thereon, the following Commissioners voted in favor thereof:

and the following voted against the same:

Whereupon said resolution was declared duly passed and adopted. Dated this 13<sup>th</sup> day of April, 2026.

\_\_\_\_\_  
Brian Romness  
Planning Commission Chairperson

\_\_\_\_\_  
Cynthia Smith Strack  
Community Development Director





# MEMORANDUM

Planning and Zoning Commission

<b>DATE:</b>	April 13, 2026
<b>FROM:</b>	Cynthia Smith Strack, Community Development Director
<b>AGENDA ITEM:</b>	2050 Comprehensive Plan Update – Community Engagement Tool
<b>BACKGROUND:</b>	<p>The City Council has been discussing the 2050 Comprehensive Plan update, including community engagement. Earlier this year the Council voiced preference for lowering costs associated with community engagement efforts. To those ends, staff has been preparing alternate engagement tools using ESRI based storymaps with embedded surveys. The EDA is reviewing a tool to gain input on what powers local business.</p> <p>The engagement tool staff is working on is entitled “Growing Together: Help Us Plan for 2050”. The tool provides background information/concepts and survey questions. Basis &amp; highlights:</p> <ul style="list-style-type: none"><li>• Belle Plaine has and is changing. Because growth is shaped by both individual property rights and broader market forces, our outreach goal is not to decide <b>whether</b> growth happens, but to guide <b>how</b> it happens. We’ll invite community members to share their voices on a balanced, value based path forward. Background provided prior to the survey will talk about <a href="#">why Belle Plaine is growing</a> and share impacts of <a href="#">different growth scenarios</a>. This information is also attached.</li><li>• The survey is The survey has been filtered to help ensure neutral language so as to reduce unproductive responses. The survey has been designed with choice architecture guided logic to help prevent contradictory responses. It is noted there is not at this point a true way to prevent the loudest voices from taking the survey multiple times. The only real way to do that is through an address-coded mailed survey or telephone survey.</li><li>• The survey will help us understand what community members most value about our physical environment. This will assist us in protecting key features while also recognizing that property owners have rights and that some level of development will continue as Belle Plaine evolves.</li><li>• Also highlighted will be choices about where and how growth occurs. Different approaches toward growth, each with its own benefits and trade-offs, will be presented. The scenarios will help us think about how land use, transportation costs, housing choices, and community character interact in different growth patterns.</li></ul>
<b>ACTION</b>	This item is for PZC information only.
<b>SIGNATURE:</b>	



## Why Belle Plaine is Growing



Economic Opportunity



Quality of Life



Near Job Centers

## Businesses Follow Population Growth

*Commercial activity appears where there are already "rooftops"*

## Emerging Industries



Logistics



Advanced Manufacturing



Data Centers

Open Land • Strong Utilities • Regional Connections

*Reflecting National Economic Trends*

## Guiding Growth



Reflect Our Values



Meet Regional Goals



Protect Key Landscapes







Promote Sustainability

*We can't stop growth, but we can manage it wisely*

Scenario	Growth Pattern	Transportation Impact	Impact on Housing Choices	Fiscal Impact (Infrastructure)	Land Area
<b>Targeted Infill &amp; Redevelopment</b>	Inward	Shorter trips, less driving Better walk/bike conditions Transit more viable	Adds missing-middle housing Supports aging-in-place Expands attainable options	Strong return on investment in existing infrastructure Lower maintenance costs	Minimal land consumption
<b>Growth in Designated Centers (Nodes &amp; Corridors)</b>	Clustered More dense in nodes	Multimodal travel improves Transit cost-effective Walkability increases within nodes	Higher-density housing near services More unit variety	Efficient infrastructure investment Strong commercial tax base	Protects open space
<b>Compact, Mixed-Use/ Smart Growth</b>	More dense Taller buildings (vertical growth)	Significant reduction vehicle miles Higher transit viability Strong walking/biking networks	Broad mix of housing types Increased supply in walkable areas	Lowest long-term infrastructure cost Highest tax value per acre	Modest land consumption Preserves natural areas
<b>Edge Expansion/ Greenfield Development</b>	Outward	Longer commutes Higher development cost for more new roads More miles of infrastructure to maintain Limited transit feasibility	Primarily single-family housing Predictable suburban pattern	High upfront infrastructure costs High infrastructure maintenance costs Lower tax value per acre	Large land consumption (sprawl) Loss of farmland/open space

# Future Growth Scenarios: *Comparing Matrix*

*Transportation • Housing • Fiscal • Environmental*

	 Growth Pattern	 Transportation	 Housing	 Fiscal	 Environmental
Targeted Infill & Redevelopment	Inward / Targeted	Less Driving	Missing-Middle Housing	Efficient Use of Infrastructure	Lower Emissions
Growth in Designated Centers	Clustered / Focused	Transit Access	Higher Density	Strong Tax Base	Rural Protection
Compact, Mixed-Use	Dense / Integrated	Walkable & Transit-Friendly	Broad Housing Mix	Cost Effective	Green Space
Employment-Driven	Targeted / Directional	Targeted Traffic	Workforce Housing	Higher Costs	Air & Noise Impacts
Edge Expansion	Outward / Dispersed	Outward Commuting	Single-Family Homes	High Infrastructure Costs	Land Loss

*How do we want our city to grow? • Which options fit our needs? • What's most important to you?*

# Belle Plaine Community Survey LOGIC FLOWCHART

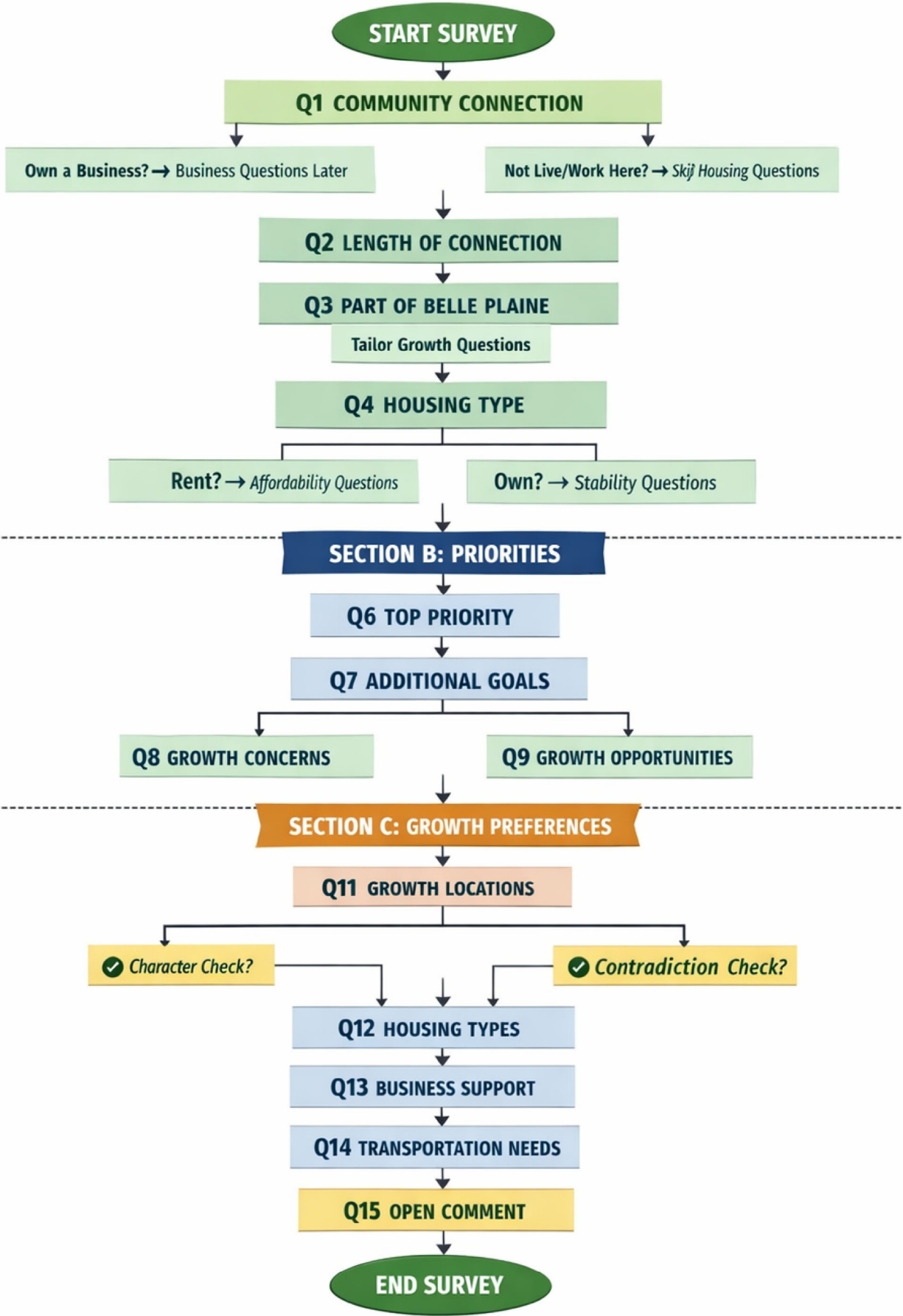



# MEMORANDUM

Planning and Zoning Commission

<b>DATE:</b>	April 13, 2026
<b>FROM:</b>	Cynthia Smith Strack, Community Development Director
<b>AGENDA ITEM:</b>	Director's Update
<b>REPORT:</b>	<p><b>Design Committee</b> The Design Committee did not meet in April.</p> <p><b>EDA</b> The EDA will meet prior to the PZC.</p> <p><b>Other</b></p> <ul style="list-style-type: none"><li>• 2050 Comprehensive Plan update</li><li>• Leading Economic Transformation (LET) Program</li><li>• Public interactive engagement planning – business environment &amp; growth</li><li>• Zoning information/assistance to four commercial entities</li><li>• Facilitate sale of city property</li><li>• Code review (zoning) assistance for building/zoning permits</li><li>• City communications</li><li>• Bonding request info prep and meetings</li><li>• Compile information for Scott County Housing and Commercial/Industrial Studies</li><li>• Discussions with residential developer</li><li>• HRA programming</li></ul>
<b>SIGNATURE:</b>	